



PRO Power Rack w/monkey bar GPR-380



Monkey bar



Optional for lat attachment and stacks



Optional : hooks / 90 degree quick adjuster

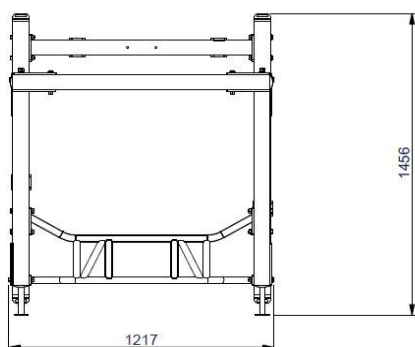

1456mm/57"(L)x1217mm/48"(W)x2087mm/82"(H)

GPR-380 + GLA-388S (lat attachment)

Freedom of movement combined with adjustable racking and safety positions make the Power Rack a must-have for those who want to strength train without compromise. The Steelflex Pro Power Rack is designed to work with all types of benches and engineered for extreme workouts. Heavy-duty 11-gauge high tensile strength steel frames feature all-4-side welded construction and oversized industrial strength hardware. Electrostatically applied powder coat finish resists chipping and scratching through the most brutal routines. If you want to get bigger and stronger fast, a Pro Power Rack is what you need.