

GLA-388 OWNER'S MANUAL

GLA-388 HARDWARE ILLUSTRATION SHEET

A1.M10X90L HEX HEAD BOLT-----[2PCS]

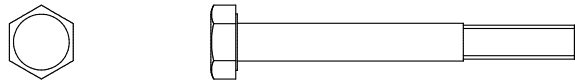

A2.M12X90L HEX HEAD BOLT-----[2PCS]

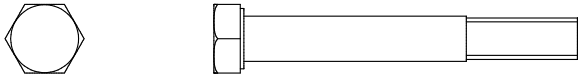

A3.M10X45L HEX HEAD BOLT-----[7PCS]

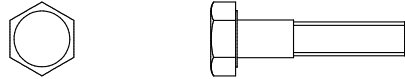

A4.M10X16L ALLEN HEAD BOLT-----[2PCS]



A5.M10X95L HEX HEAD BOLT-----[2PCS]



A6.M10X100L HEX HEAD BOLT-----[2PCS]

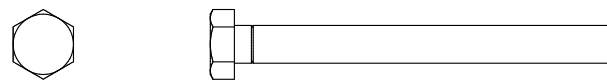

A7.BALL PIN (8250-071)-----[1PCS]

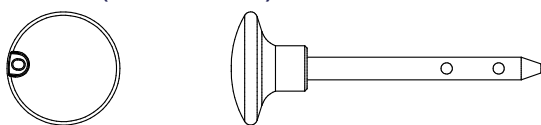

A8.3/8"X2"L CAP HEX HEAD BOLT-----[1PCS]

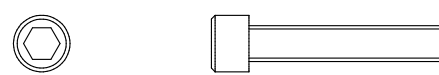

B1.M10 NYLON LOCK NUT-----[13PCS]



C1.M10(I.D) WASHER-----[26PCS]

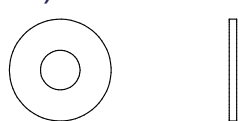

C2.M12(I.D) WASHER-----[2PCS]

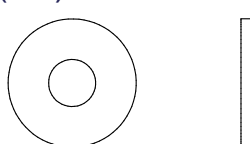

C3.3/8" SPRING WASHER-----[1PCS]

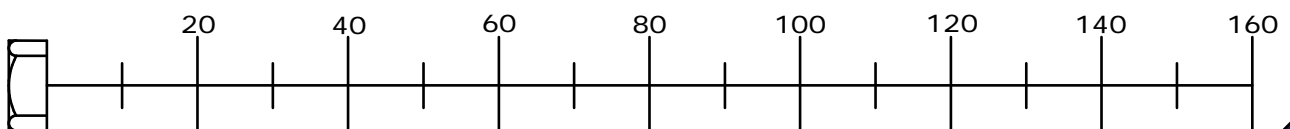

GLA-388 PARTS ILLUSTRATION SHEET

D1. FOOT CAP (9211-026)-----[3PCS]

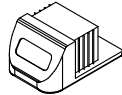

D2. END CAP (9211-049)-----[2PCS]



D3. RUBBER DOUNT (9310-010)-----[2PCS]



D4. SPRING SNAP LINK (8810-001)-----[3PCS]



D5. WEIGHT STACK PIN LANYARD-----[1PCS]



D6. Ø110 PULLEY (9213-002C)-----[7PCS]



D7. Ø20XØ10X27L STEEL BUSHING (8530-011)-----[4PCS]



D8. END CAP (9211-087)-----[2PCS]



D9. END CAP (9211-084)-----[2PCS]



D10. Ø3/4" SHAFT COLLAR (9211-046)-----[2PCS]



D11. 2925mm STEEL CABLE-----[1PCS]

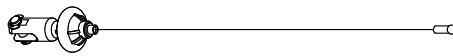

D12. 3350mm STEEL CABLE-----[1PCS]



D13. 23" STEEL CHAIN-----[1PCS]



D14. END CAP (9260-021)-----[4PCS]



D15. CABLE END SHAFT (8890-010)-----[1PCS]



D16. RUBBER DOUNT (9310-012)-----[2PCS]



GLA-388 PARTS ILLUSTRATION SHEET

A [1PCS]

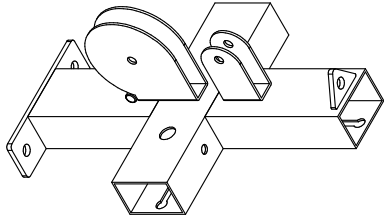

B [2PCS]

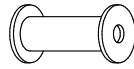

E [1PCS]

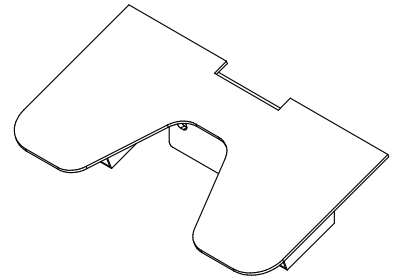

C [2PCS]

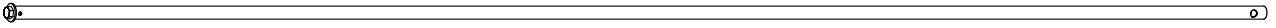

D [1PCS]

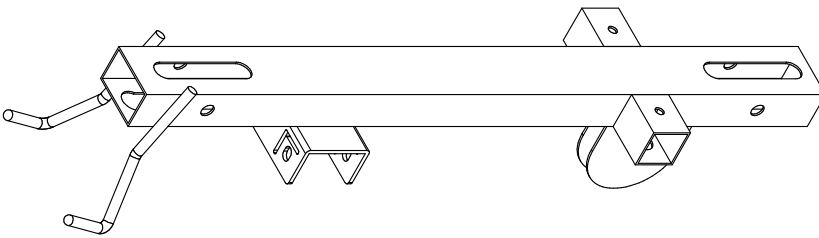

H [2PCS]



M [1PCS]

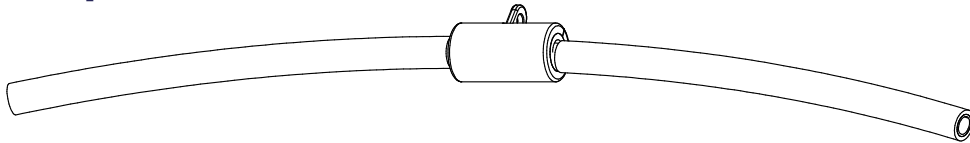

P [1PCS]

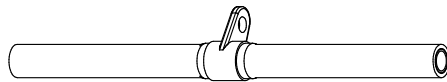

F [1PCS]

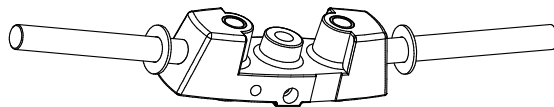

G [1PCS]

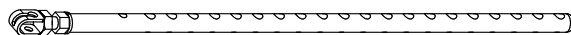

GLA-388 ASSEMBLY INSTRUCTIONS

STEP 1

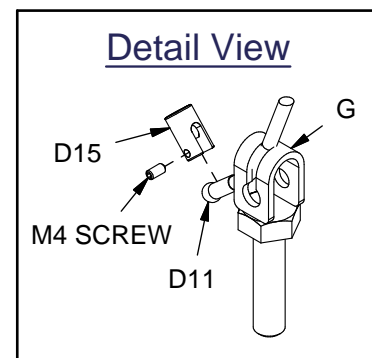
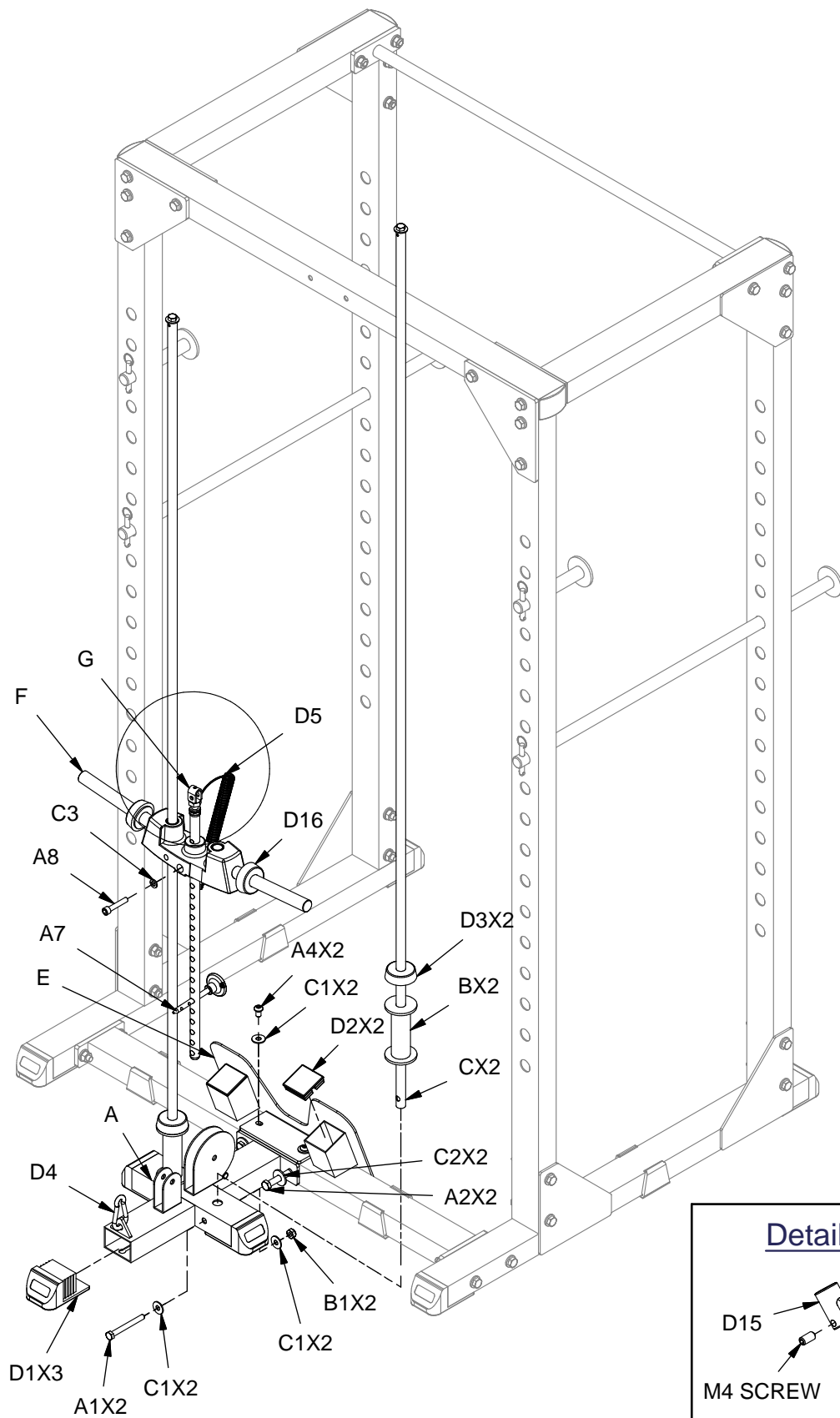

GLA-388 ASSEMBLY INSTRUCTIONS

STEP 2

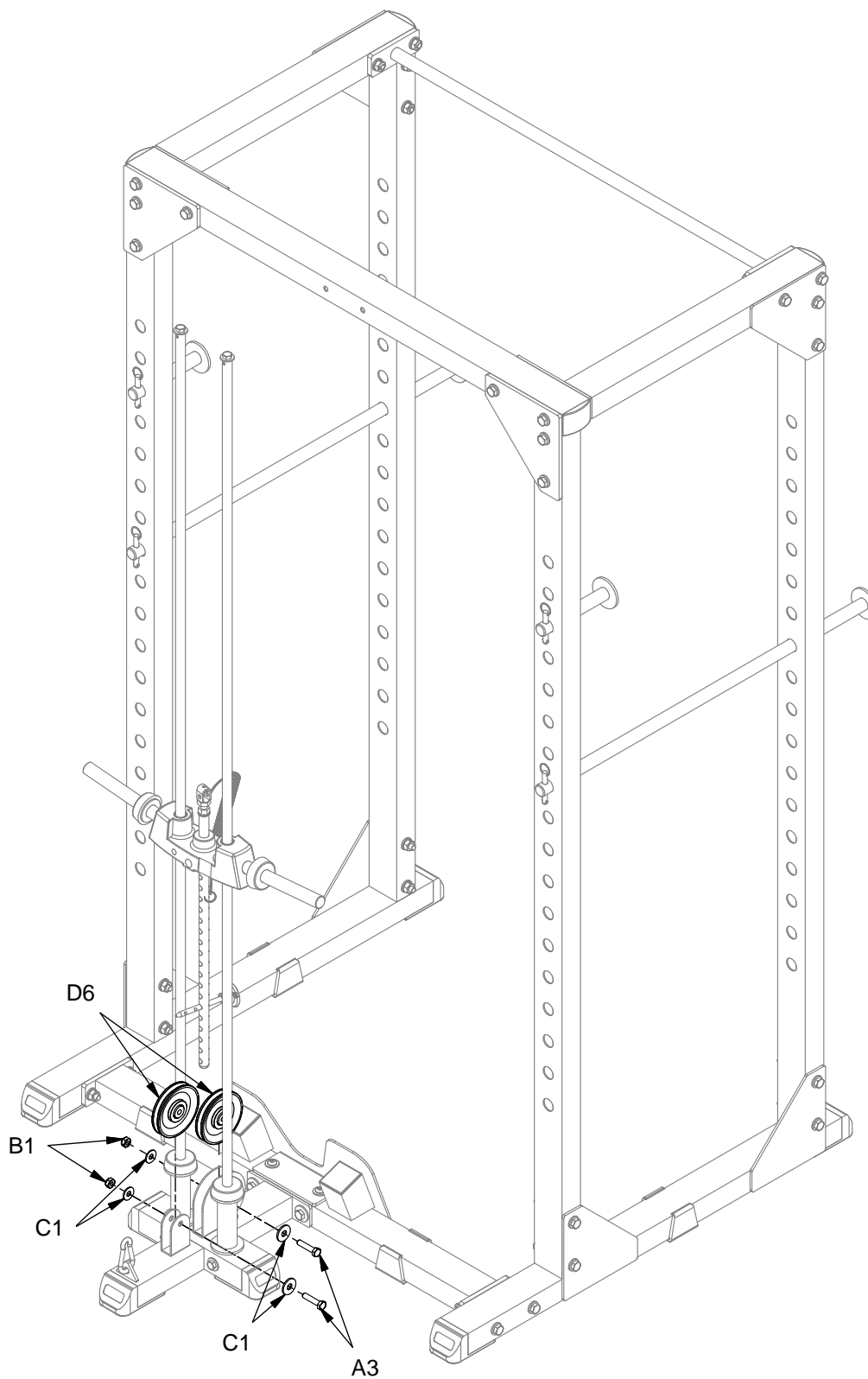

GLA-388 ASSEMBLY INSTRUCTIONS

STEP 3

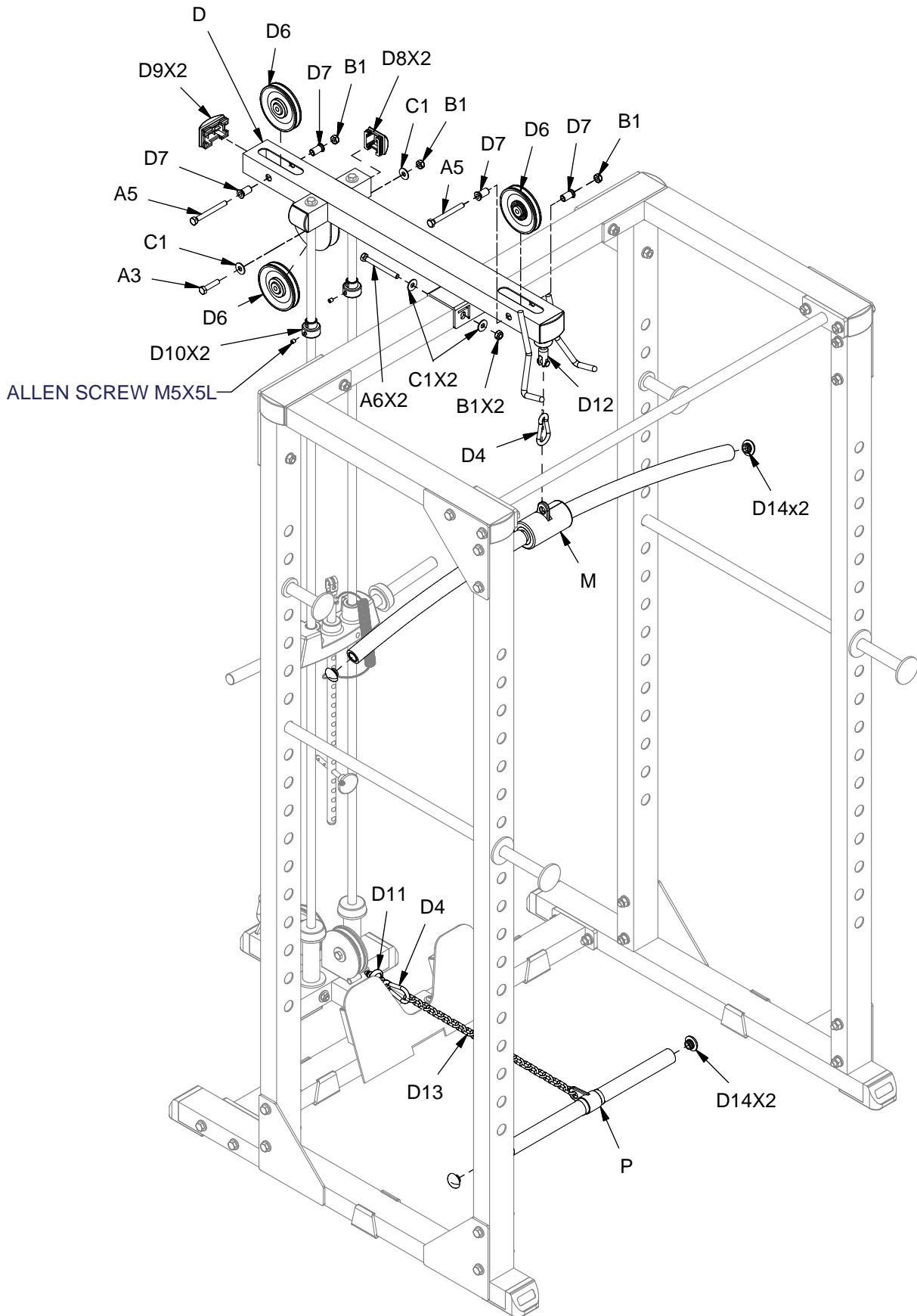

GLA-388 ASSEMBLY INSTRUCTIONS

STEP 4

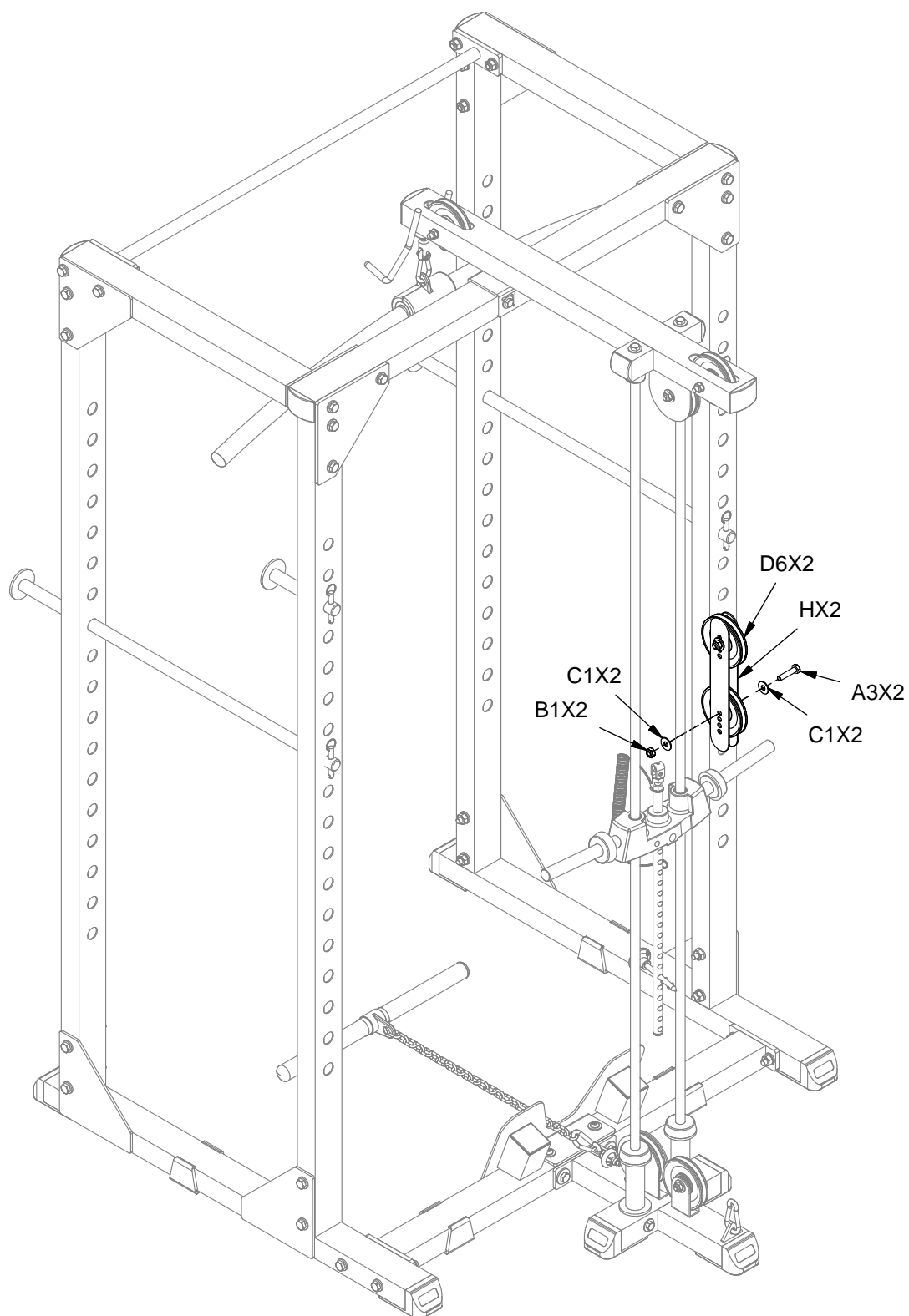

GLA-388 ASSEMBLY INSTRUCTIONS

STEP 5

